

MV Motor & Drive Solutions in Power Generation

metals

cranes

mining

testing

oil & gas

renewable
energy

**power
generation**

cement

Introduction to TMEIC

A Global network

TMEIC is built on a proud heritage in the industrial automation, control and drive systems business. TMEIC's global business employs more than 2,200 employees, with sales exceeding \$2.4 billion, and specializes in Metals, Oil & Gas, Material Handling, Power Generation, Cement, Mining, Paper and other industrial markets.

TMEIC Corporation, headquartered in Roanoke, Virginia, designs, develops and engineers advanced automation/ variable frequency drive systems, motors and generators.

Customer Service

At TMEIC, our focus is on the customer, working to provide superior products and excellent service, delivering customer success every project, every time.

Variable Frequency Drives in Electric Power Plants

Every step of the way, from the fuel to the grid, variable frequency drives (VFDs) are used to smoothly start large motors and continuously adjust the speed as required by the process. Induction and synchronous motors driving

boiler feed pumps, forced draft fans, induced draft fans, service water pumps, and conveyors use VFDs to provide high power, accurate speed control, and efficient flow control with significant energy savings.

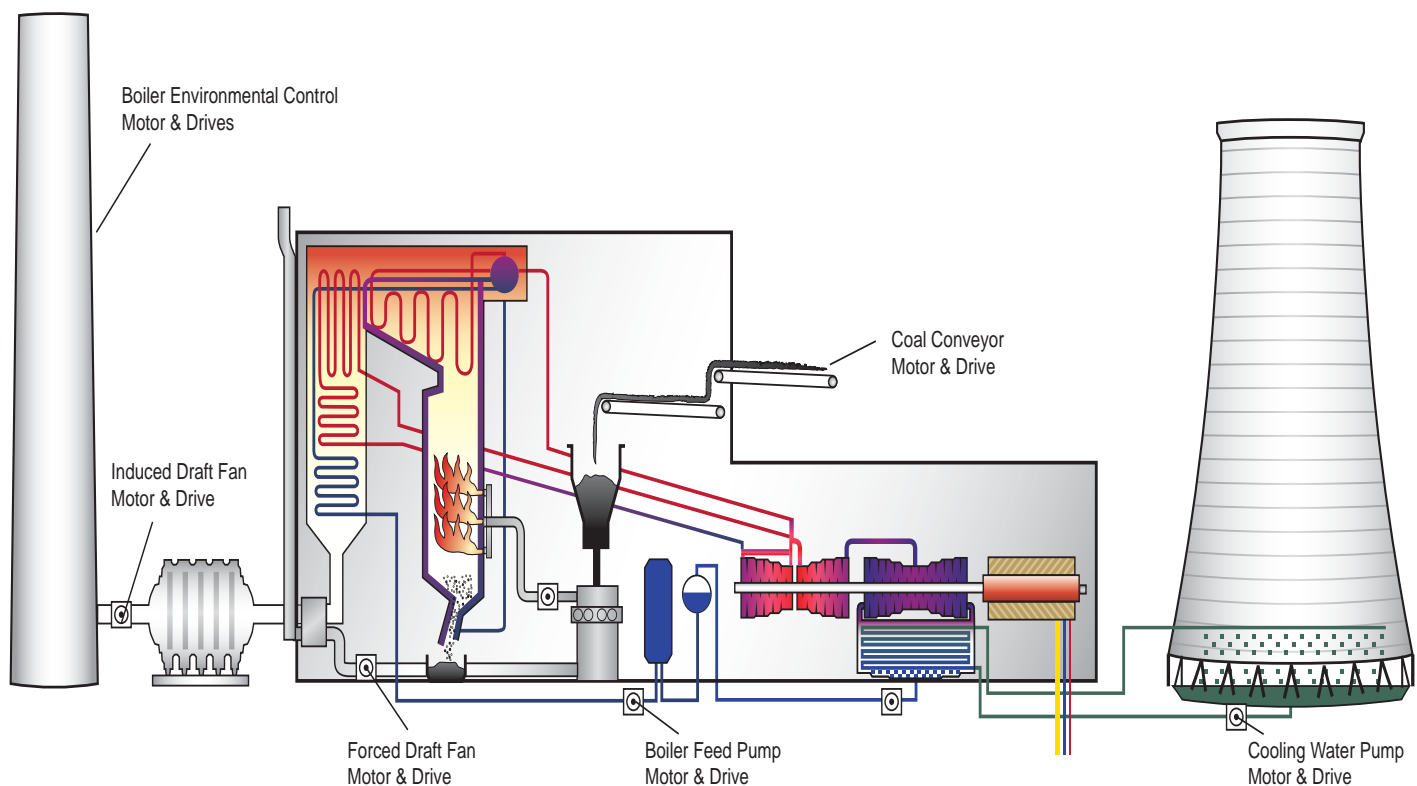

Controlling fan flow by adjusting speed avoids wasting energy in flow control vanes, dampers, and louvers. When large flows must be controlled and motor energy consumption is significant, varying the motor speed is the answer. With large machines, the electrical power

savings can amount to hundreds of thousands of dollars per year. In addition, the drives smoothly start the motors, protecting them against starting inrush currents, thus avoiding thermal stress and extending motor life.

Typical Drive Applications in the Power Plant

Variable frequency drives are used to control the speed of fans, pumps, and mills in power plants. VFDs are also used to smoothly start large motors, synchronize, and connect them across the line. The following seven pages describe four typical applications and present the reasons why electric drives were chosen. These selected drive applications are:

- Induced and forced draft fans
- Cooling tower fans and pumps
- Boiler feed pumps
- Service water pumps
- Boiler environmental control pumps/fans

Case Study 1. Drives for Multiple Induced Draft Fans

This 1987 power plant had four large 3800 hp boiler ID fans driven by four Load Commutated Inverters (LCI) drives and synchronous motors in each of two units. A fan power upgrade to 6600 hp was recently made to accommodate new pollution control equipment known as SCR (Selective Catalytic Reduction), which reduces nitrogen oxides in the flue gas from burning coal. A fifth LCI drive was configured as a spare to be connected to any of the four motors as required.



The customer had several requirements when making this major upgrade to the 600 MW power station:

- Replace the original motors with higher power 6600 hp synchronous motors for 4160 V ac operation and 1200 rpm.
- Ensure the replacement drives have at least the same high reliability as the original LCIs, and the latest control equipment.
- Provide ability for the drive to soft start the motor and thereby reduce the current inrush and resulting overheating.
- Ability for the standby drive to be switched to any of the four motors if required.

After reviewing their alternatives, the company decided to place the order for the drives, motors, and electrical system with the original vendor - TMEIC.

Advantages of the Variable Frequency Drive and Synchronous Motors



High Reliability – Based on the customer’s 20 years of trouble-free operating experience with the LCI, the high reliability is proven. In addition, the ability to back up any of the drives with the standby drive yields very high system availability.

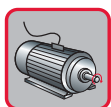

Smooth Motor Starting – The LCI controls the rotor field (through the exciter) and the stator current to provide a smooth starting profile without exceeding rated volts and amps, thereby protecting the motor against overheating.



Cost Savings – The synchronous motor and LCI combination is one of the highest efficiency drive systems available, resulting in energy cost savings over the life of the system.

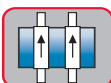

Water Cooling Technology in the Drive – The water cooling system reduces maintenance, drive room cooling costs, and ambient noise. The system is redundant and water hoses don’t need to be disconnected for bridge service, see photo on next page.

Case Study 2. Induced Draft Fan on Boiler

The ID fan creates furnace air flow, which must be continuously varied to match the fuel flow. The process control system continuously monitors process conditions such as fuel feed, inlet air temperature, flue oxygen content, and required fuel-air ratio. The control system then directs the fan to provide the air flow for optimum combustion.



Traditional flow control methods use constant speed motors with mechanical flow reducing devices such as:

- Inlet louvers (dampers) in the ducting
- Outlet louvers (dampers) in the ducting
- Flow guide vanes in the fan casing
- Variable slip clutches in the fan drive shaft
- Hydraulic variable speed transmissions

These mechanical solutions have significant disadvantages:

- High energy consumption at reduced flow rates
- Mechanical wear and required maintenance
- Generation interruptions due to mechanical problems
- Limitations on motor starting duty

The electrical solution replaces the mechanical equipment with a Dura-Bilt5i MV VFD. This brings a number of advantages.

Advantages of the TMEiC Dura-Bilt5i MV VFD System



Very High Reliability – The Dura-Bilt5i MV uses 3,300 Volt Insulated Gate Bipolar Transistors (IGBT) allowing a simpler, more reliable inverter design. Since mechanical flow devices are not used, process interruptions caused by mechanical failures are minimized.



Energy Savings – Elimination of the air flow losses through the dampers is usually the most compelling reason for applying a Dura-Bilt5i MV drive. The ID fan power can be several thousand hp and using a drive to vary air flow can result in energy savings of over \$100,000 per year, as described on the next page.

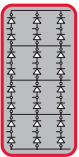

Power System Friendly – The converter is a 24-pulse diode rectifier with a performance exceeding the requirements of the IEEE 519-1992 standard for Total Harmonic Distortion (THD). This means that other equipment connected to the power system is not adversely affected by harmonic frequency disturbances.



Heat Pipe Cooling – For most frames the IGBTs in the three inverter legs are cooled with heat pipe technology, which maintains uniform working temperature, prolongs the semiconductor life, reduces cooling fan power and noise, and saves valuable floor space in the plant.

Energy Savings using a TMEIC Variable Frequency Drive Fan System

Variable flow can be provided by varying fan RPM to precisely match process operating conditions. The variable frequency drive provides variable fan speed which varies the air flow according to the system resistance.

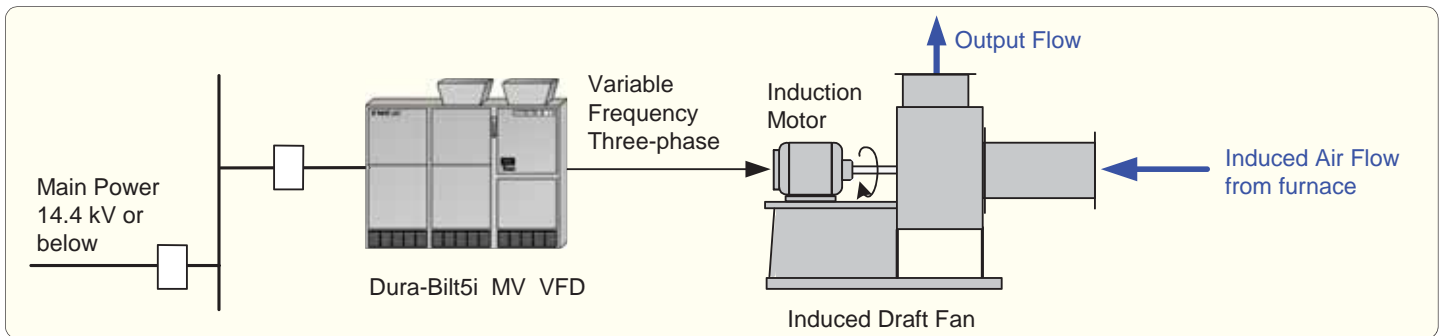

The first chart shows how different fan speeds are used to select the proper operating points A through E on the system resistance curve. Depending upon the size of the boiler, the required ID fan output power can vary from a few hundred hp to several thousand hp. The second chart shows a system using mechanical dampers to achieve flow control. Pairs of flow and pressure operating points correspond to points A through E.

Power level percentages shown are total input power including all motor, transformer, fan, and system losses as percentages of required fan output power. The energy deltas (vertical lines) allow calculation of energy savings and drive cost justification. A table of expected annual operating times and power level differences is shown below. Energy cost factors for the site are applied and the annual savings calculated.

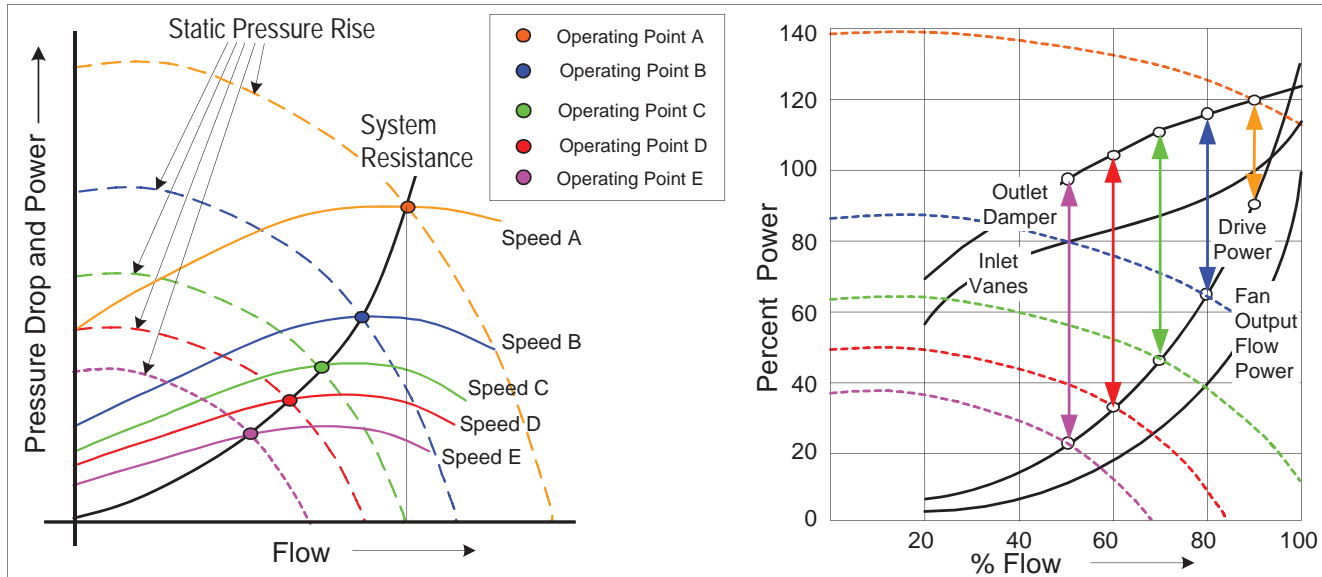

Ref Point	Required Flow %	% Power Using Outlet Damper Control	% Power Using Adjustable Speed Drive	Delta % Power Saved	% Time on Annual Basis	% Saved on Annual Basis
A	90	120	91	29	15	4.35
B	80	117	66	51	25	12.75
C	70	111	46	65	25	16.25
D	60	103	34	69	20	13.8
E	50	96	23	73	15	10.95
Total Annual % Energy Consumption Savings						58.1

Savings. Based on the annualized percent savings in the table, an ID fan system with 1,000 hp output, operating for 8,000 of 8,760 hours per year, at an energy cost of \$0.035 per kWh, saves:

$$1000 \times 0.746 \times 58.1\% \times \$0.035 \times 8000 = \$121,359$$

If installed added costs of drive equipment are \$150,000, the payback period will be only 15 months. A good return on investment!

Case Study 3. Boiler Feed Pumps

Boiler feed flow has to be controlled to match the boiler load and maintain steam drum level. In the past, boiler feed pumps have been driven either by a variable speed steam turbine, or a fixed speed electric motor using a throttling valve to control feed flow. Occasionally hydraulic variable transmissions were used. These approaches have disadvantages as described below. Using a VFD and electric motor has a number of benefits, also listed below.



Steam Turbine Drive Disadvantages

- Special mechanical maintenance is required on a regular basis.
- Turbine can be expensive, especially if it is custom designed.

Fixed Speed Electric Motor Disadvantages

- High energy losses in the throttling valve at lower flows is expensive.
- Motor is subjected to hard starts with resulting thermal stresses on the windings with reduced motor life.

Hydraulic Transmission Disadvantages

- The energy losses are significant at lower speeds of less than 80%.

After reviewing their alternatives, the company decided to place the order for the drives, motors, and electrical system with the original vendor - TMEiC. The system diagram is shown on the next page.

Advantages of the Variable Frequency Drive and Synchronous Motors



Energy Savings and Reduced Maintenance – Elimination of the flow losses through the throttling valve and its associated maintenance are usually the most compelling reasons for applying a variable frequency drive. The feed pump power can be several hundred hp or more, depending on the plant rating, and using a drive to vary feed flow can result in considerable energy savings, as described on the next page.



High Reliability – Based on years of customer experience, the high reliability of AC drives is proven. TMEiC MV drives for utility applications have an MTBF from 12 to 16 years.

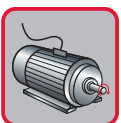

Smooth Motor Starting – The VFD controls the motor input frequency and current to provide a smooth starting profile without exceeding rated volts and amps, thereby protecting the motor against overheating, extending motor life, and eliminating voltage dips. A VFD eliminates restrictions on the number of starts per hour that apply to across the line starts.

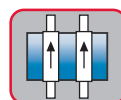

Heat Pipe or Water Cooling Technology in the Drive – The advanced technology cooling system maintains uniform working temperature, prolongs semiconductor life, reduces cooling fan power and noise, and saves valuable floor space in the plant.

Energy Savings using a TMEIC Variable Frequency Drive Pump System

Flow can be controlled to match process operating conditions by varying pump RPM. The variable frequency drive system does not require a flow control (throttling) valve. Costs for the fixed and variable speed cases are compared below.

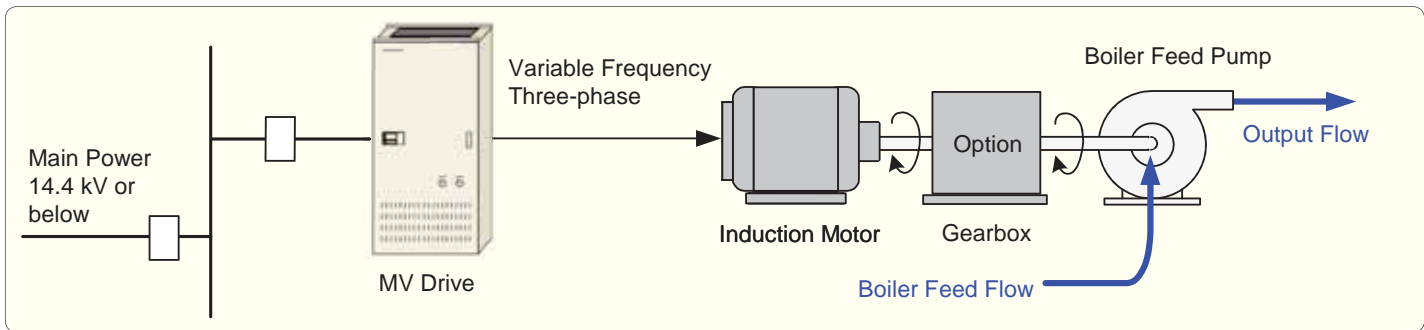

Throttling Valve Flow Control. The example curves below are for a 600 hp pump for low head requirements. In the pump curves, operating at 2400 GPM and 3560 RPM requires 550 hp (refer to point A). Reducing the flow to 1200 GPM with a throttling valve, at constant 3560 RPM speed, causes the pump to move back to point B; this point requires 400 hp.

Alternative Variable Pump Speed Flow Control (No Valve). Using a VFD, reducing the pump speed from A to C reduces the flow to 1200 GPM, but the head is much reduced, from 800 ft to 200 ft and the power required is only 70 hp. This is 330 hp less than the first case, and represents the power which was lost in the throttling valve. If much time is spent at low flows the energy savings using a VFD are considerable.

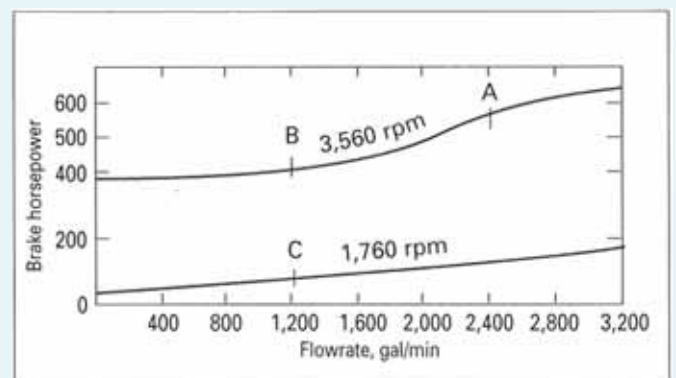
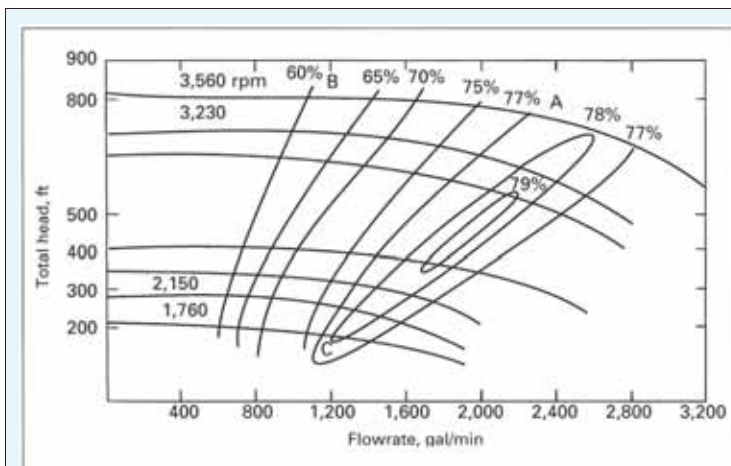

Typical pump head, flow, speed & power characteristics

Energy Cost Savings with VFD

In this example, the pump was consuming 400 hp at B but at C is only consuming 70 hp, so the energy saved by not throttling is 330 hp. As a quick estimate, assume operation at point C for 60% of the time and at point A for 40% of the time. With 90% combined motor efficiency and power costs of \$0.05 per kWh, annual savings will be just under \$60,000. Significant! Of course the larger the motor the larger the savings will be, and since energy costs will probably continue to rise, the life time savings will be large.

Typical VFD and Motor data:

- Drive efficiency – Dura-Bilt5i MV - 96.5%
- Motor efficiency – Induction - 95.7%
– Synchronous - 98.1%
- Drive power – Dura-Bilt5i MV - Up to 7,000 hp
- Output Voltage – Dura-Bilt5i MV - 2,000 to 4,200 Vac

Case Study 4. River Water Pumps for Cooling

Flow of cooling water through the main turbine condenser varies with the volume of steam entering, which is proportional to the generating load. This cooling flow usually comes from the cooling tower and has to be controlled based on the load. Make up water compensates for evaporation in the cooling tower, and is pumped from a nearby river or lake. The make up water flow also varies with the load and must be controlled.



Typical vertical water pumps

This utility customer had three river water pumps for make-up water and planned to install new drives on two of them. The requirements were:

- 4160 Vac drives, each of 900 hp.
- Each drive to have a bypass allowing the motor to run directly off the line at full speed if required.
- Nominal pump speed 885 rpm with a 30-100% speed range.
- Drives to be housed in a power house located close to the intake structure and pumps.
- Power house to be air conditioned to allow operation of the drives with an external ambient temperature of 40°C (104°F).

Dura-Bilt5i MV drives were chosen for this upgrade because they operate at 4,160 Vac, are reliable with a MTBF of 16 years, have a small footprint, and have built in control for synchronous bypass.

Cooling water requirements will also decrease as the cooling water temperature decreases. Pumps driven by VFD's can efficiently accommodate these changes in flow requirements.

The cooling water pumping system has several levels of built-in redundancy. Both drives have a bypass allowing the motor to run directly off the line at full speed if required. Either drive can vary its pump speed to produce the desired combined flow to the cooling tower.

Advantages of the Dura-Bilt5i MV Pumping System



Very High Reliability—The Dura-Bilt5i MV uses 3,300 Volt Insulated Gate Bipolar Transistors (IGBT) allowing a simpler, more reliable inverter design. As a result of the very high reliability, the Dura-Bilt drive offers a 16 year MTBF.

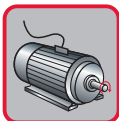

Smooth Motor Starting – The VFD controls the motor input frequency and current to provide a smooth starting profile without exceeding rated volts and amps, thereby protecting the motor against overheating, extending motor life, and eliminating voltage dips.

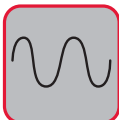

Synchronous Bypass –The drive has built-in control to automatically synchronize the motor frequency and phase with the main power and close the contactors to allow the motor to run at full speed when required.

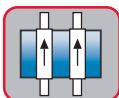

Heat Pipe or Water Cooling Technology in the Drive –The advanced technology cooling system maintains uniform working temperature, prolongs semiconductor life, reduces cooling fan power and noise, and saves valuable floor space in the power house. Heat pipes are used in large frame sizes.

TMdrive-Navigator - Simple Configuration and Maintenance

The TMdrive-Navigator tool helps you maintain TMEIC drives yourself. Engineers and technicians are empowered to understand how the drive works and what the drive is doing. Any user can easily access current drive expertise and know-how.

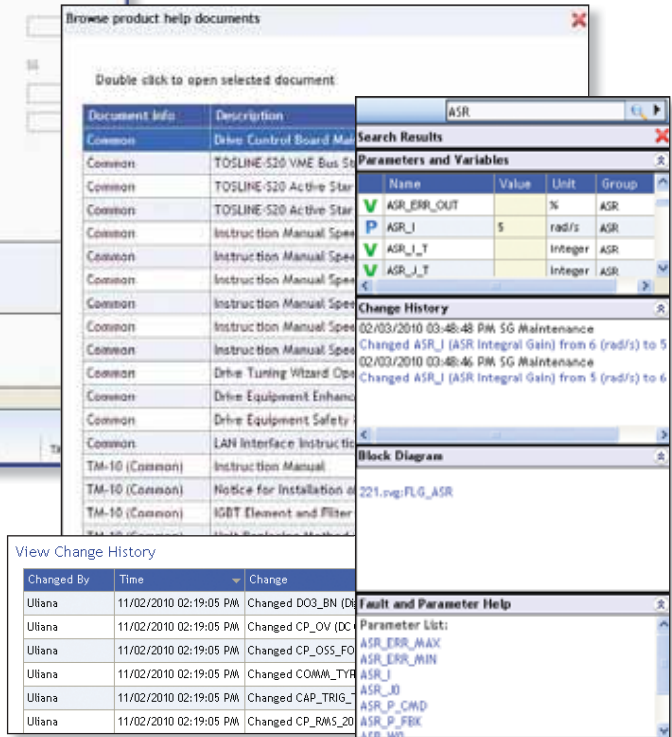
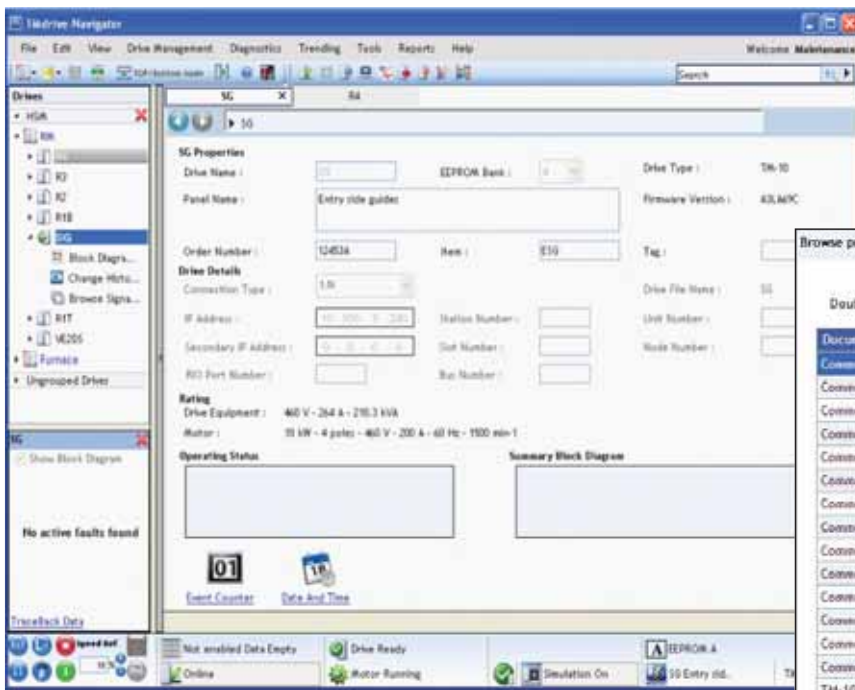

Desk-top like search technology links topical signal lists, block diagrams, help files, product documentation, change history, and user notes. Windows techniques facilitate navigation within a drive and across the system. The status of all drives is always in view.

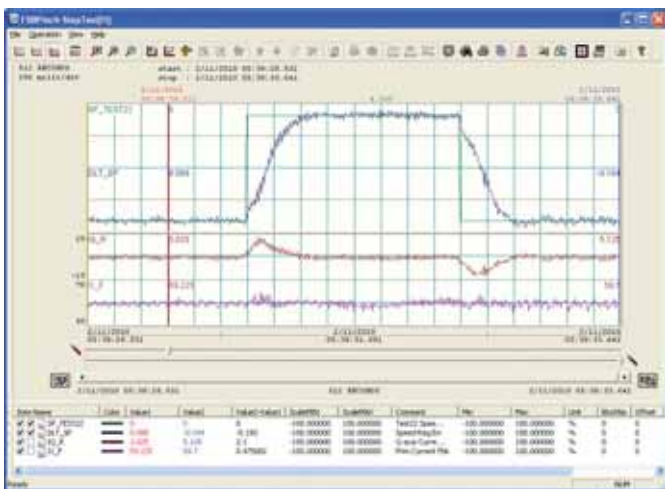

Live block diagrams provide a real-time graphical view of drive functions. Functions can be configured directly from the graphical view. Product documentation is integrated right into the tool. Users may even capture their own notes to benefit future troubleshooting.

Compatible with:

- Windows XP, Vista 7
- Windows Server 2003, 2008

High-speed data is automatically captured and saved in the event of a drive fault. Users may also capture high speed data based on their own trigger conditions or perform high resolution real-time trending.

Fault data can be automatically “pushed” to key users. The client-server architecture allows access to high performance data from remote locations – with the same resolution as if you were in the plant.

Wizards support tuning of drive functions.

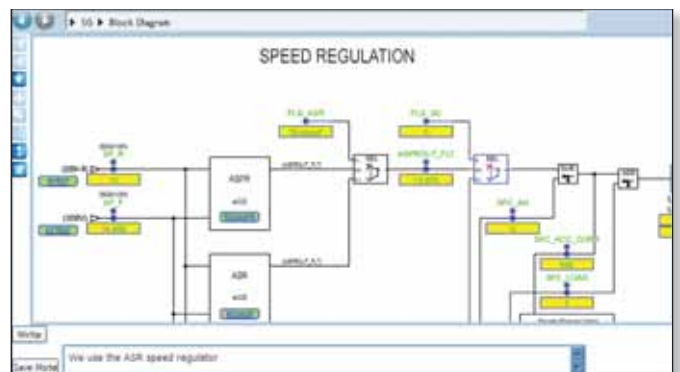

Introduction to TMEIC Motors

TMEIC combines the best of Toshiba and Mitsubishi-Electric's experience in building motors that goes back over 100 years. TMEIC's motor offering includes induction motors from a few hundred horsepower, up to synchronous motors over 100,000 hp, driving a wide range of industrial applications such as pumps, fans, grinding, conveyors, and compressors. In addition to applications directly connected to utility power, TMEIC motors can be matched with Variable Frequency Drives for ease of starting and for speed control. The VFD allows motor speeds as high as 12,000 rpm.

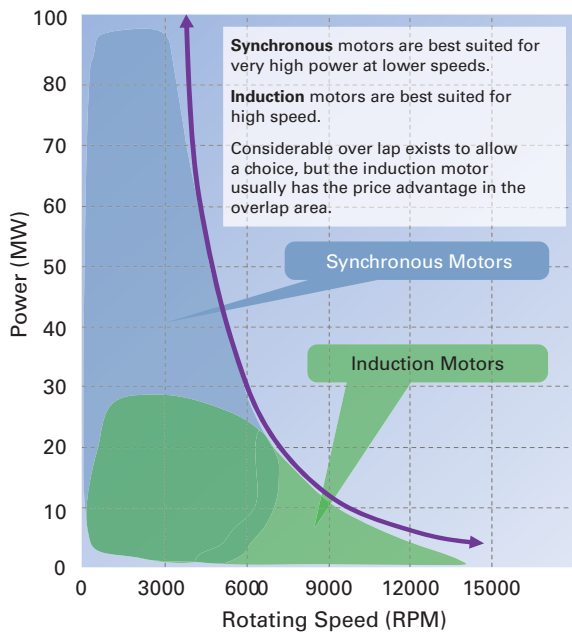

Expansion of the oil and gas industry has created demand for large motors to drive gas compressors and oil pumps. These motors are located in the production areas and on interstate pipelines, and are usually designed with explosion protection. For special applications such as driving large compressors and blowers, motor ratings can reach or exceed 100,000 hp. Meeting the demand for large motors for the metals industry, TMEIC has produced large synchronous and induction motors for the operation of steel rolling mills. The power levels for these motors go up to about 10 MW. They are covered in a separate brochure.

Features

High Reliability resulting from use of proven design technology, manufacturing expertise, wide use of robotics, tight quality control, and testing

High Efficiency resulting from detailed analysis of the electromagnetic field patterns and ventilating air flows

High Strength Insulation applied by robotic insulation winding and oversized epoxy resin vacuum impregnation tanks creates strong support and insulation

High Mechanical Strength through use of static and dynamic strength analysis of stator frame, rotor, shaft and bearings. Motor shafts are made of forged steel with high tensile strength

Benefits

Many years of excellent trouble-free service under difficult working conditions

Low electrical losses for high power conversion efficiency

Withstand surge and minimizes electrical shorts and winding fatigue failure

Minimizes mechanical deflection and vibration for longer equipment life

High-Quality Design, Manufacturing, and Testing

TMEIC produces high-quality motors by employing the best design, manufacturing, and test procedures. Advanced computer aided design and analysis allows motor performance to be predicted in advance. The world class manufacturing automation system produces high-quality parts, on time, with no exceptions. These automated systems produce components and assemblies meeting the highest quality requirements, delivery schedule, and long life.

Continuous Improvement

The manufacturing system has specified standards, and the actual performance is measured against these. Continuous quality improvement is built in, with product quality steadily improving as a natural outcome.



Large Stator Assembly

Excellent Motor Design Tools – Extensive CAD and Computerized Finite Element Analysis

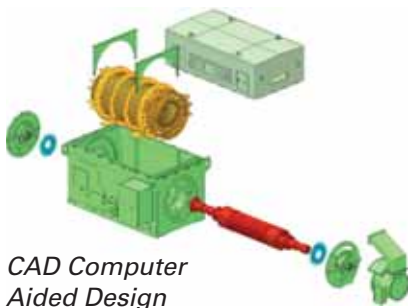

CAD Computer Aided Design

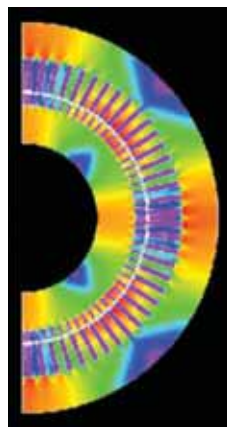

FEM Electromagnetic Analysis

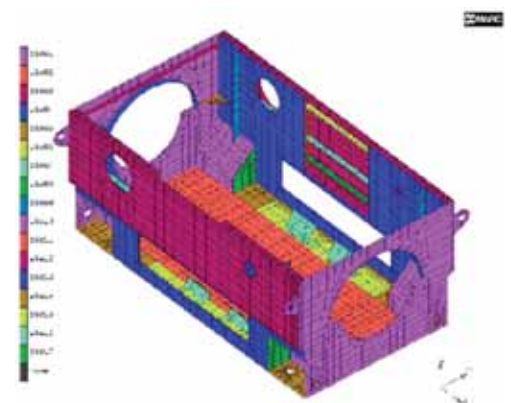

FEM Natural Frequency Analysis

TMEIC motor engineers make extensive use of computer aided design to produce their detail and assembly drawings, both two-dimensional and three-dimensional.

Enhanced computerized Finite Element Analysis is used to analyze and optimize electromagnetic field strength, rotor stress and dynamics, frame natural frequencies, cooling air flow patterns, and internal temperatures.

High-Quality Manufacturing – Computer Control and Robotics

Manufacturing procedures make use of computer control and robotics to increase the speed of the work, maintain accuracy, and ensure repeatability of the operations. Examples include:

- Air duct plate robotic assembly
- Segmented core lamination robotic assembly
- Round core lamination robotic assembly
- Rotor field core robotic assembly
- Computer controlled core stamping



Robotic Stator Core Lamination Stacking





World-Class Motor Test



TMEIC's fully instrumented computer automated test (CAT) facilities allow motors to be load and speed tested. The example facility shown here was built to test large motors and drives at high speed. This back-to-back test arrangement used:

- Variable frequency drive to provide power and desired speed to the test motor
- Generator to load the test motor
- Variable frequency drive to recycle power back to the supply



Motor Specifications

Product	Induction Motors			
	LV and MV TM21™ -FII	MV Motors TM21-G	MV Motors TM21-MII	MV Motors TM21-L
Typical View				
Power	37-1,400 kW (50-1,870 hp)	Up to 23,000 kW (30,800 hp)	Up to 3,550 kW (4,750 hp)	Up to 18,500 kW (25,000 hp)
Speed	Up to 3,600 rpm	Up to 3,600 rpm	Up to 3,600 rpm	Up to 3,600 rpm
Voltage	Up to 6.9 kV	2 – 11 kV	2 – 11 kV	2 – 13.8 kV
Enclosure	Totally Enclosed Fan Cooled – TEFC/IP55	Weather Protected II- WP/II/IP24W Totally Enclosed Air-to-Air-Cooled – TEAAC/IP54/IP55/IP56 Totally Enclosed Water-to-Air-Cooled– TEWAC/IP54/IP55/IP56	Open Drip Proof – ODP/IP22 Weather Protected II- WP/II/IP24W Totally Encl. Air to Air Cooled –TEAAC/IP55 Totally Encl. Water to Air Cooled –TEWAC/IP55/56 Totally Encl. Separately (Pipe) Ventilated – TESV/IP55/56	Open Drip Proof – ODP/IP22 Weather Protected II-WP/II/IP24W Totally Encl. Air to Air Cooled –TEAAC/IP55 Totally Encl. Water to Air Cooled –TEWAC/IP55 Totally Encl. Separately (Pipe) Ventilated – TESV/IP55
Classified Area	Exn, Extc, Exd	Exn, Exe, Exp	Exn, Exe, Exp, ExtD	Exn, Exe, Exp, ExtD
Rotor	Aluminum die cast rotor, or Copper rotor bars	Copper rotor bars	Alum. die cast rotor Opt. copper rotor bars	Copper rotor bars
Bearing Options	Ball & roller bearings, grease lubrication	Ball & roller bearings, grease lubrication Sleeve bearings	Ball & roller bearings, grease lubrication Sleeve bearings	Ball & roller bearings, grease lubrication Sleeve bearings
Length	920 to 2,720 mm (36 to 107 in)	1,910 to 4,930 mm (75 to 194 inch)	1,580 to 4,130 mm (62 to 162 in)	2,400 mm and up (95 in and up)
Available Standards	IEC, NEMA, BS, AS, CSA, API	IEC, NEMA, BS, AS, CSA, IS, JEC	IEC, NEMA, BS, AS, CSA, API	IEC, NEMA, BS, AS, CSA, API
Major App.	Fans, Blowers, Compressors, Conveyors	Fans, Blowers, Compressors, Mills, Conveyors	Fans, Blowers, Compressors, Mills, Conveyors	Fans, Blowers, Compressors, Mills, Conveyors

Vertical Motors TM21-VL & VLL	High Speed (Custom design)	Medium-High Power (Custom design)	High-Speed (Custom design)
			
Up to 6,500 kW (8,700 hp)	Up to 8,000 kW (10,720 hp)	Up to 80,000 kW (107,240 hp)	Up to 80,000 kW (107,240 hp)
Up to 1,800 rpm, option > than 30 poles	Up to 11,900 rpm on VFD power	Very low speed up to 3,600 rpm	Up to 6,500 rpm
2 –13.8 kV	2.3 -11 kV	3.3 –13.8 kV	Up to 13.8 kV
Open Drip Proof – ODP/IP22 Weather Protected II-WPII/IP24W Totally Enclosed Air to Air Cooled –TEAAC/IP55 Totally Enclosed Water to Air Cooled –TEWAC/IP55	Totally Enclosed Air to Air Cooled–TEAAC/IP55 Totally Enclosed Water to Air Cooled –TEWAC/IP55 (Blower ventilated)	Totally Enclosed Air-Air Cooled–TEAAC/IP55 Totally Enclosed Water to Air Cooled –TEWAC/IP55	Totally Enclosed Water to Air Cooled –TEWAC/IP55
Exn, Exe, Exp	Exn, Exe, Exp	Exp	Exp
Copper rotor bars	Aluminum alloy rotor bars	Cylindrical solid rotor for two- pole, salient pole all others	Cylindrical solid rotor, two-pole
Antifriction bearings Tilting pad bearings	Magnetic bearings Tilting pad bearings	Sleeve bearings	Sleeve bearings Tilting pad bearings Magnetic bearings
2,500 to 6,000 mm (98 to 236 in)	Aprox 2,100 mm (83 in)	Approx. 8,100 mm (319 in)	8,100 mm (319 in)
IEC, NEMA, BS, AS	IEC, NEMA, BS, AS	IEC	IEC
Pumps	Gearless Compressors	Mills, Blowers, Pumps, Compressors	Blowers, Gearless Compressors

A Family of Drives up to 11 kV



TMdrive-10e2



Dura-Bilt5i MV



TMdrive-XL55



TMdrive-MVe2

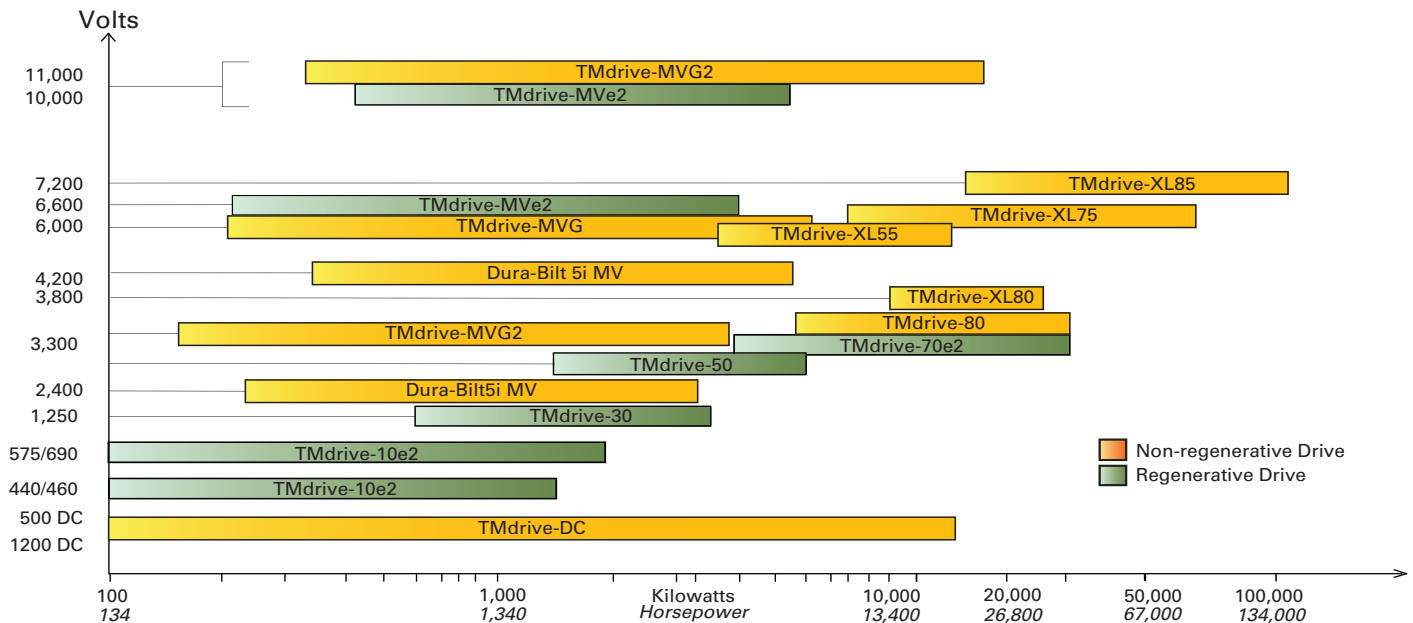

TMEiC Family of AC and DC System Drives

Over 50 Years Drive Experience. Starting with DC drives, we later added AC drives, such as the Innovation Series drives and the new technology Tosvert, Dura-Bilt, and TMdrives. Since 1979 over 2 million hp of TMEiC AC drives have been installed and are in service, representing the largest installed base of MV drives of any manufacturer.

Drive Voltages up to 11 kV. The family of drives offers voltages all the way from 440 V with the TMdrive-10 up to 11 kV with the TMdrive-MVG.

The Highest Reliability. TMEiC drives provide the highest reliability based on field experience and customer satisfaction surveys.

Significant Investment in Drive Technology. TMEiC's Tosvert, Dura-Bilt, and TMdrive products represent a large investment in LV and MV drive technology, including development of semiconductor devices such as the IEGT and GCT.

Configuration Software. The TMdrive Navigator world-class configuration software is used on all TMEiC drives. Live block diagrams and tune-up wizards streamline commissioning and maintenance activities.

Large Spare Parts Stock. TMEiC's parts depots stock the line of MV drive parts and provide rapid delivery to your plant anywhere in the world.

Project Engineering



TMEIC's Engineering Team

Experienced Drive Engineering Team

The drive engineering team is experienced in the electric power industry and gained its experience working in the plants with technicians and mechanical suppliers. This engineering background, coupled with state-of-the-art drive technology, enables TMEIC to consistently meet the demanding requirements of the industry.

Experienced drive engineers jointly define the drive equipment and control strategy with customer engineers. This is followed by detailed design of the system, control logic, and configuration of the drives.

Project Life Cycle Process Minimizes Risk

We understand that delay in commissioning is very expensive, so we take steps to hold our startup schedule:

- Project management provides a single point of contact from initial order to final commissioning
- Complete factory tests include applying power to the bridges and exercising the control
- The local commissioning engineers are included in the project team, allowing a seamless transition from the factory to your plant

Local Commissioning Team Ensures Knowledgeable Ongoing Service

Our field service organization is broad and deep with extensive experience in the industry providing you with a strong local service presence for startup and ongoing service work, both in North America and overseas.

Global Customer Support Network

Comprehensive technical service is provided by our Customer Support Organization, staffed by TMEIC service engineers with offices and spare parts depots across the globe.

In North and South America

Customers are supported by the TMEIC Corporation service personnel, design engineers and Spare Parts Depot in Virginia, and the TMEIC Factory in Japan.

In Europe

TMEIC service engineers service all drive systems in Europe, supported by the European TMEIC Spare Parts Depot.

In Asia and the Pacific Rim

TMEIC services drive systems throughout China, India and the Pacific Rim, supported by multiple Field Engineers, Spare Parts Depots, and the TMEIC factory in Japan.

Remote Drive Diagnostics

TMEIC Corporation supports drive customers through the **Remote Connectivity Module (RCM)**, a remote diagnostic service link with the TMEIC design and service engineers in Roanoke, Virginia. The RCM enables seamless integration between your drives and our engineers.

Remote System Diagnostics

TMEIC's remote system diagnostics tool, included in level 1 software, offers a quick path to problem resolution. System faults are automatically identified, and provide an integrated view of product, process and system information. TMEIC design and service engineers in Roanoke, Virginia, can analyze the data and provide steps for resolution.

Remote Diagnostic Service reduces Mean Time To Repair (MTTR)

Remote diagnostic service offers protection for your investment, by reducing downtime, lowering repair costs and providing peace of mind. Remote diagnostics requires an internet connection between your plant and TMEIC Corporation for retrieval of fault logs and files to diagnose drive or system issues.

Customer Service

1-877-280-1835 (USA and Canada)

+1-540-520-2010 (International)

www.tmeic.com/CS

Global Office Locations:

TMEIC Corporation

Roanoke, Virginia, USA

Email: GI@tmeic.com

Web: www.tmeic.com

TOSHIBA MITSUBISHI-ELECTRIC INDUSTRIAL SYSTEMS CORPORATION (TMEIC)

Tokyo, Japan

Tel: +81-(0)3-3277-5511

Web: www.tmeic.co.jp

TMEIC Europe Limited

Uxbridge, Middlesex, United Kingdom

Email: info@tmeic.eu

Web: www.tmeic.eu

TMEIC Industrial Systems India Private Limited

Andhra Pradesh, India

Email: inquiry_india@tmeic.in

Web: www.tmeic.in

TOSHIBA MITSUBISHI-ELECTRIC INDUSTRIAL SYSTEMS CORPORATION (TMEIC)

Beijing, China

Email: sales@tmeic-cn.com

Web: www.tmeic-cn.com

TMEIC – Sistemas Industriais da América do Sul Ltda.

São Paulo/SP, Brasil

Tel: +55-11-3266-6161

TOSHIBA MITSUBISHI-ELECTRIC INDUSTRIAL SYSTEMS CORPORATION (TMEIC)

Shanghai, China

Email: sales@tmeic-cn.com

Web: www.tmeic-cn.com

TMEIC Asia Company Ltd.

Kowloon Bay, Hong Kong

Web: www.tmeic.com

TMEIC Asia Company, Ltd. Rep. Office

Kaohsiung, Taiwan

Web: www.tmeic.com

All specifications in this document are subject to change without notice. This brochure is provided free of charge and without obligation to the reader or to TMEIC Corporation. TMEIC Corporation does not accept, nor imply, the acceptance of any liability with regard to the use of the information provided. TMEIC Corporation provides the information included herein as is and without warranty of any kind, express or implied, including, but not limited to, any implied statutory warranty of merchantability or fitness for particular purposes. The information is provided solely as a general reference to the potential benefits that may be attributable to the technology discussed. Individual results may vary. Independent analysis and testing of each application is required to determine the results and benefits to be achieved from the technology discussed.

TMdrive is a registered trademark of TOSHIBA MITSUBISHI-ELECTRIC INDUSTRIAL SYSTEMS CORPORATION.

TMEIC is a registered trademark of TOSHIBA MITSUBISHI-ELECTRIC INDUSTRIAL SYSTEMS CORPORATION.

TM is a registered trademark of TOSHIBA MITSUBISHI-ELECTRIC INDUSTRIAL SYSTEMS CORPORATION.